



**STANDARD CONSTRUCTION**

MATERIAL:  
26 GAUGE ASTM A-653 HOT-DIPPED GALVANIZED  
STEEL SHEET

STANDARD SIZES:

MODEL	LENGTH	WIDTH	DEPTH	GAUGE	BUNDLE QTY.
WSP10	10"	3 1/4"	36"	26	15'
WSP12	12"	3 1/4"	36"	26	15'
WSP14	14"	3 1/4"	36"	26	15'

**FEATURES**

GALVANIZED STEEL PROVIDES EXCELLENT CORROSION  
RESISTANCE AND LONGEVITY.

OPTIONS: CUSTOM SIZES AVAILABLE.

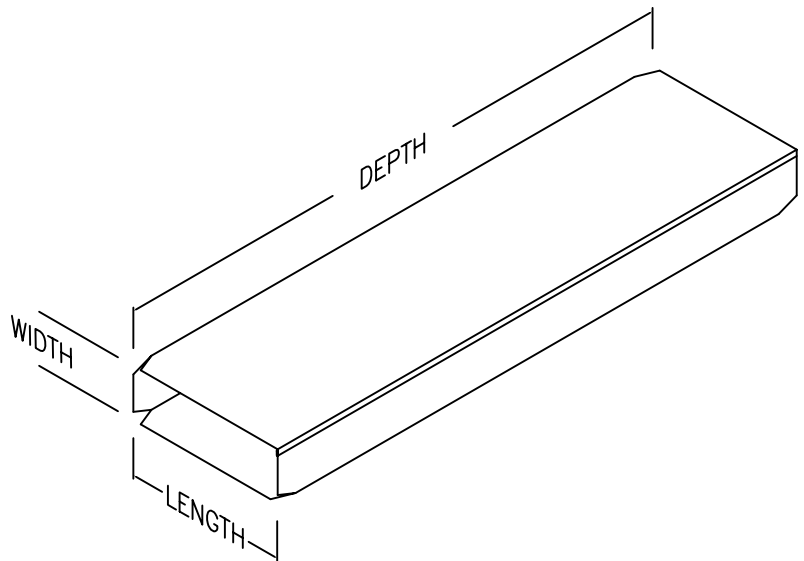

JOB NAME:
LOCATION:
ARCHITECT:
ENGINEER:
CONTRACTOR:
CONTACT MIAMI TECH INC. FOR ADDITIONAL INFORMATION OR WITH SPECIAL REQUIREMENTS.  3611 NW 74TH ST MIAMI, FL 33147 PHONE: 305-693-7054 FAX: 305-693-6152  WEB: WWW.MIAMITECH.COM EMAIL: SALES@MIAMITECH.COM

**WSP**

WALL STACK PIPE  
PRODUCT SPECIFICATIONS

NOTE: ALL DRAWINGS SUBJECT TO CHANGE WITHOUT PRIOR NOTICE.



DRAWN BY: AF	DATE: 10/31/07	SCALE: NOT TO SCALE
CHECKED BY: IG	DATE: 10/31/07	REVISION: 1

DRAWING NO.  
**WSP**